



The Town of
Leesburg,
Virginia

MICHAEL E. TOMPKINS
Director of
Planning, Zoning & Development

25 West Market Street ■ P.O. Box 88 ■ 20178 ■ 703-777-2420 ■ Metro: 703-478-1821 ■ FAX: 703-771-2724 ■ www.leesburgva.org

December 20, 2000

Mr. Bhoopendra Prakash, P.E.
The Plan Source
8565-C Sudley Road
Manassas, VA 20110

Dear Mr. Prakash,

The letter serves as your official notification of the action taken by the Leesburg Board of Architectural Review (B.A.R.) on the application, CASE BAR 00-96 for a H-2 Certificate of Appropriateness, at the regularly scheduled meeting on December 18, 2000.

The Board of Architectural Review approved your application for an amendment to the sign plan of Shenandoah Shopping Center for signs for the Exxon located at 984 Edwards Ferry Road, N.E. subject to the elimination of the tiger logo's on the gas pumps. Drawings or projects may not be altered without prior approval of the Leesburg Board of Architectural Review.

If have any questions regarding your sign permit applications, please contact Kevin Lawlor, Assistant Zoning Administrator at (703) 771-2765.

Sincerely,

Kristie Lalire
Staff, Board of Architectural Review

KL/ame

cc: Kevin Lawlor, Assistant Zoning Administrator

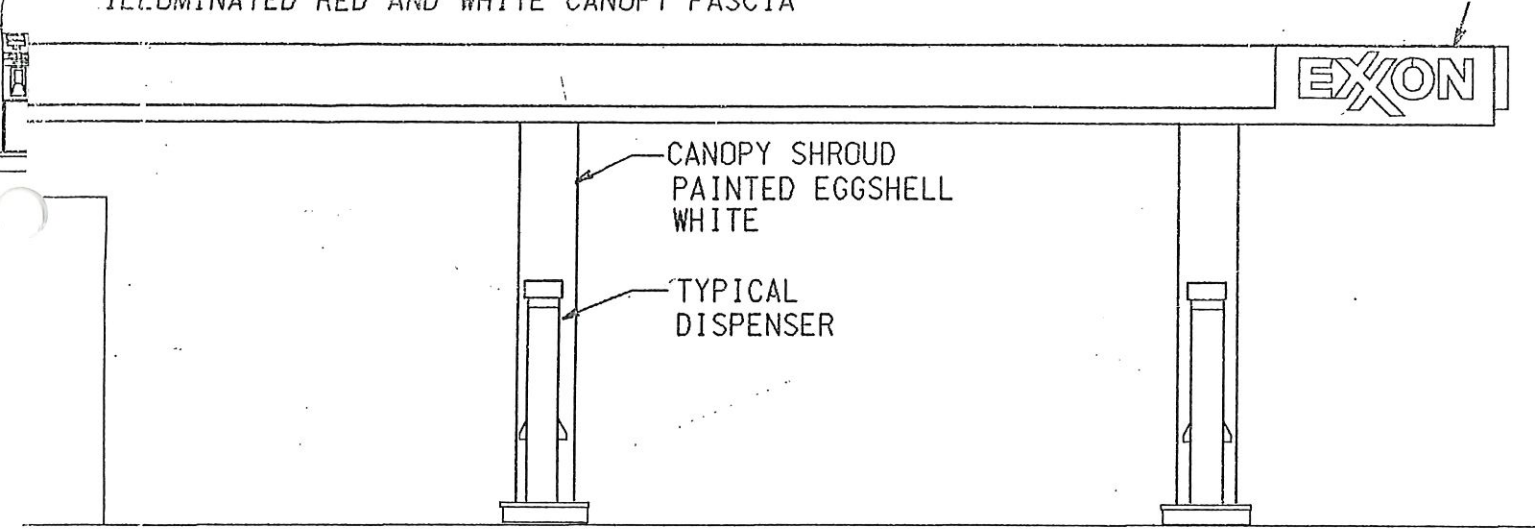

CANOPY ELEVATIONS

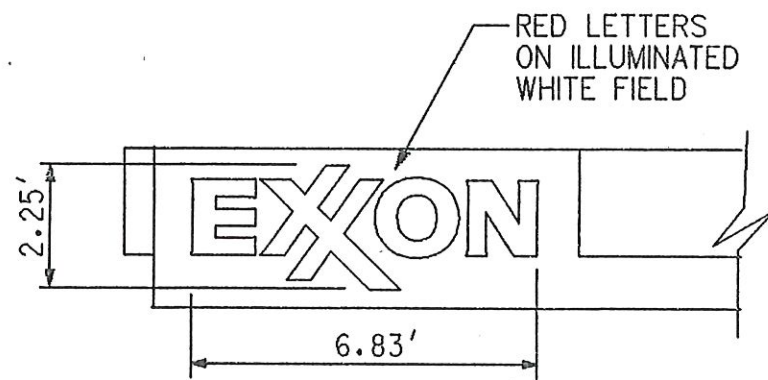

CANOPY FASCIA SIGN

15.36 SF



ExxonMobil Corporation

CANOPY UPGRADE PROGRAM

BOARD OF ARCHITECTURAL REVIEW

984 EDWARDS FERRY ROAD

LEESBURG, VIRGINIA

RS No:	2-5854
Scale:	AS NOTED
Date:	OCTOBER 11, 2000
Tracking No:	NONE

Designed By:	GP	Filename:	2-585
Drafted By:	GP	SHEET	
Checked By:	PP	1 of	

1 of			
------	--	--	--



The Plan Source

8565-C Sudley Road
Manassas, VA 20110-3811

Engineers
Planners
Permit Consultants

Tel: (703) 330-0954
Fax: (703) 335-9062

ILLUMINATED
RED EXXON LOGO

ILLUMINATED RED AND WHITE CANOPY FASCIA

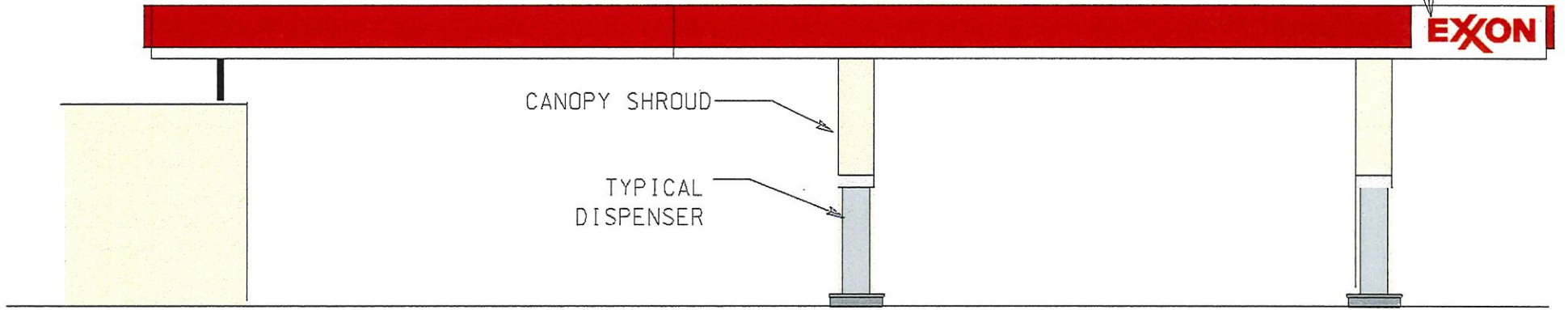

ILLUMINATED RED AND WHITE CANOPY FASCIA

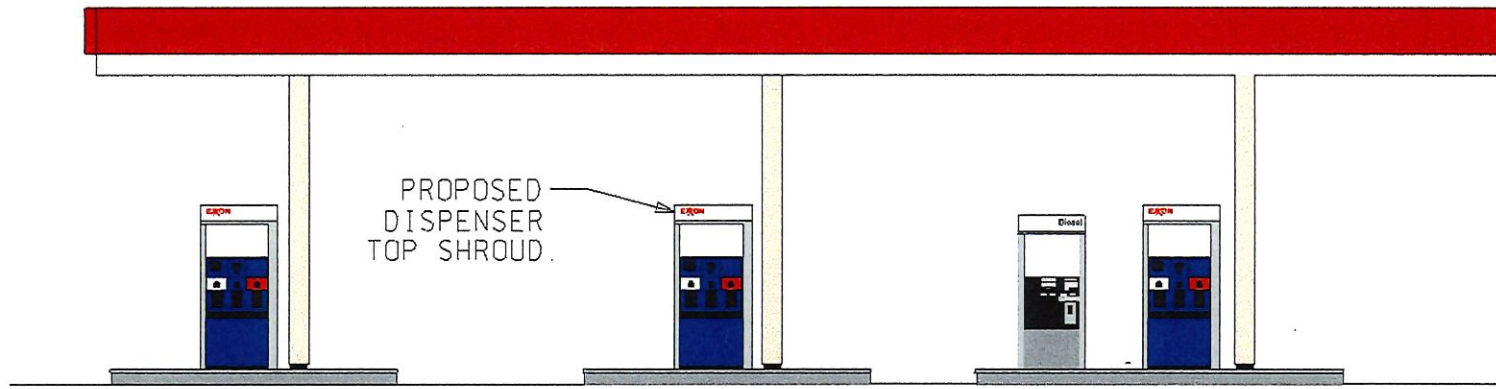



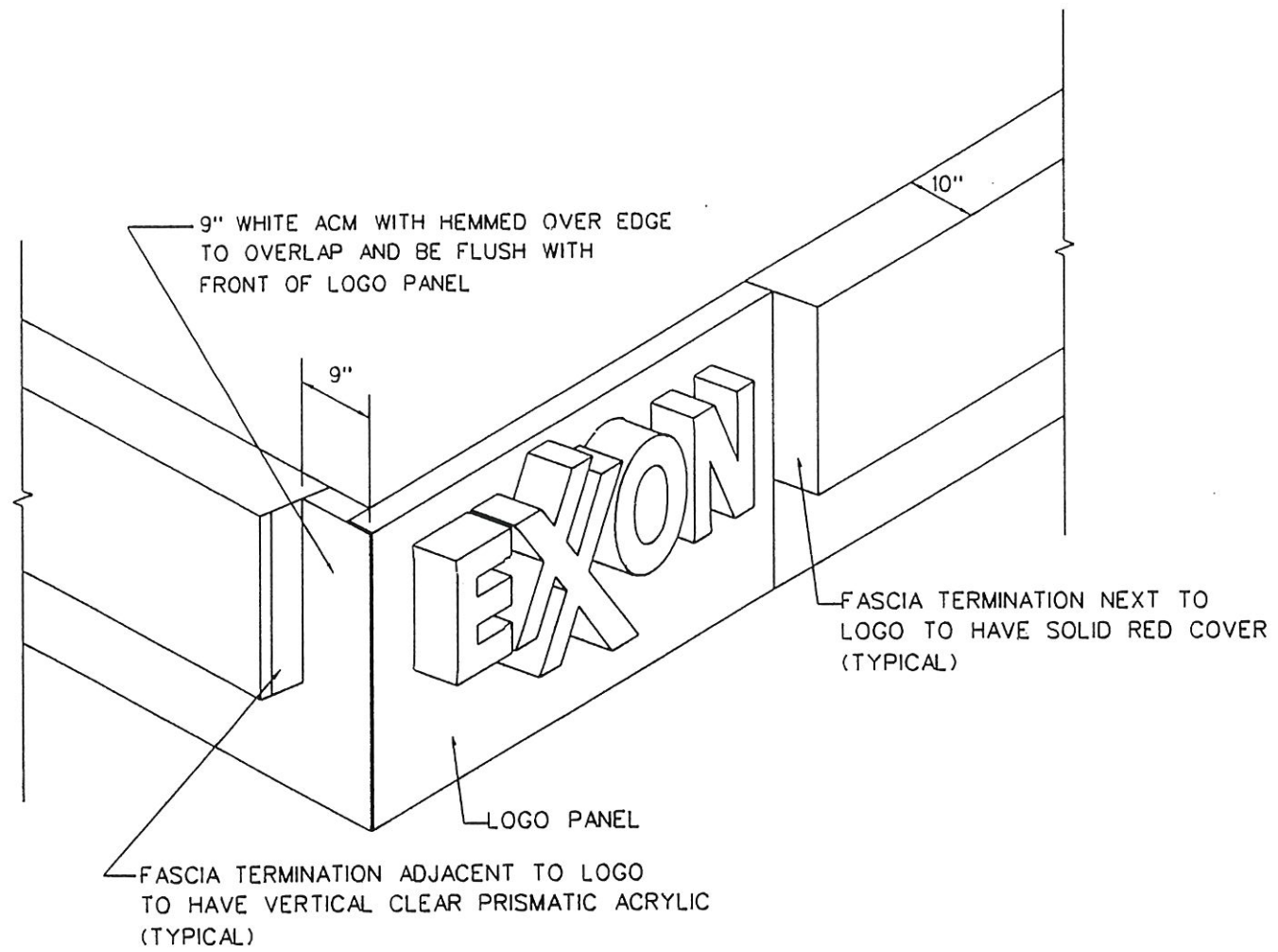

G EXXON LOGO CORNER
3 N.T.S.

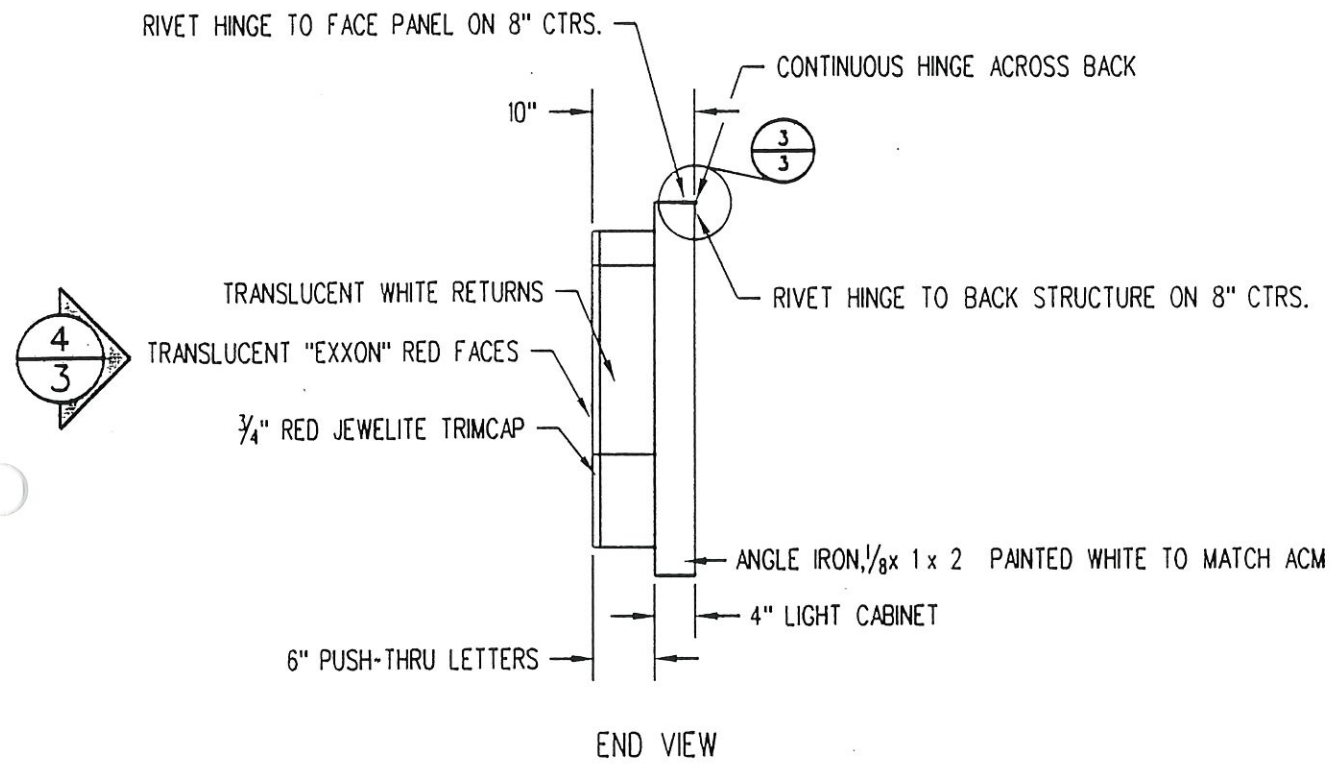

(1/3) CROSS SECTION AT LOGO SIGN BOX
 1 1/2" x 1'-0"

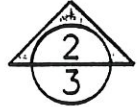
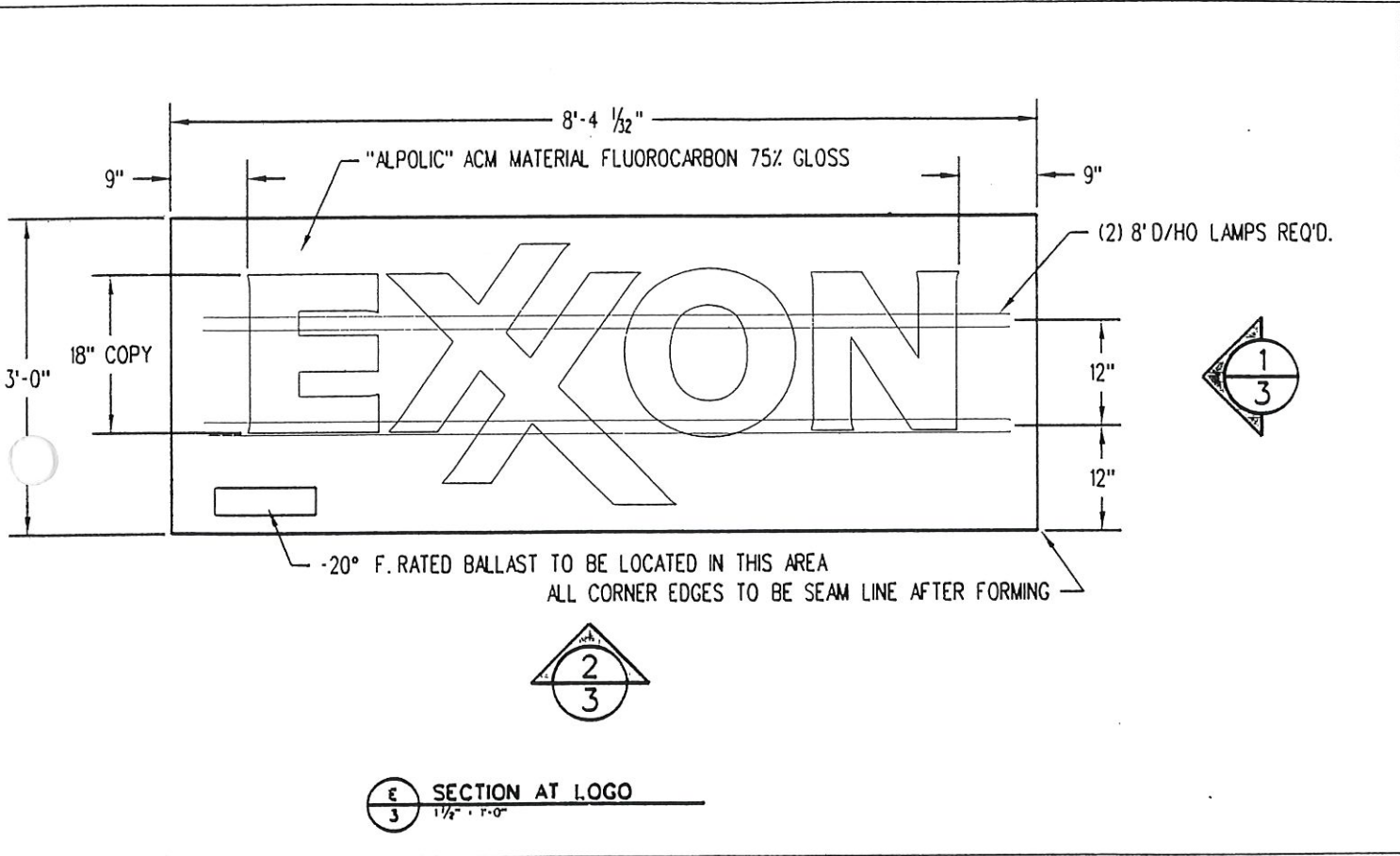

SECTION AT LOGO
1 1/2" x 1'-0"

GENERAL NOTES

ACM Panels are to be minimum 96" lengths. To be constructed of Alpolic Exxon White 75% Gloss Fluorocarbon ACM Finish.

System shall be all aluminum construction. Shall consist of a field tension system, with a field tolerance of 3" per side. System shall contain vertical extrusions every 24" to which ACM shall be adhered. System shall have positive drainage to canopy substructure and water dam to eliminate forward water runoff. All tensioning systems shall be approved by the fascia material supplier. System shall not have fasteners into gutter.

All lamps to be 8' High Output Daylight White Fluorescent Bulbs, with minimum overlap of 6". Shorter bulbs may be used at corners, no vertical lamps are required. Ballasts shall be Advance or Magnatek.

Minimum Brightness: 5.0 Footcandles (Anywhere within the red area of the sign face)
Uniformity of Illumination: All readings within the red area must fall within ±20% of the mean (average) reading across the face.

All signs designed for 30 psf positive and 30 psf negative per square foot wind load.

Routed Face Panels to be Alpolic ACM (Aluminum Composite Material) Exxon White - Fluorocarbon 75% Gloss.

Sign is to be illuminated with 2 8' Daylight High Output Lamps spaced 12" O.C. Ballast to be rated for -20 degrees Fahrenheit. Ballasts are to be manufactured by Exxon Approved Manufacturers.

Illuminated fascia details illustrated are from U.S. Patent Number 4,955,928 system produced by Signstrut, Ltd of Columbus, OH. Other approved fascia systems will vary in construction details and methods.



The Town of Leesburg
INTEROFFICE MEMORANDUM
DEPARTMENT OF PLANNING, ZONING AND DEVELOPMENT

TO: THE BOARD OF ARCHITECTURAL REVIEW DATE: BAR MTG 11/20 00

FROM: PRESERVATION PLANNER RE: AGENDA ITEM #19

ISSUE:

19. **CASE BAR 00-96**

Request for approval of an amendment to the sign plan of Shenandoah Square shopping center for new signs for the Exxon Station located at 984 Edwards Ferry Road NE, zoned B-3.

APPLICANT: Greg Peters, The Plan Source

The applicant is requesting approval of changes to the canopy sign of the Exxon Station in the Shenandoah Square Shopping Center. The new sign would consist of an illuminated, red, 2.25-foot-high Exxon Sign on the canopy; the addition of white with red text tops to the pumps advertising Exxon and a change in the color of the trim of the monument sign from black to gunmetal gray. The proposal also includes the Tiger logos on the gas pumps, which the Zoning Department has determined exceeds the number of allowable signs.

As in the case of the Sheetz station across the street, the Board may not consider the building that in this case includes the canopy. In this case the canopy color is being changed no doubt in response to the construction of Sheetz across the street so that the building can become a sign. This is a good example of a case where competing advertisements escalate in color and sign size to try to become more visible.

This shopping center has a comprehensive sign plan but it is not located in the H-2 Corridor (Leesburg Corner has a comprehensive sign plan and is located in the H-2 Corridor). In this case, the BAR has purview over signs only not the site plan or architecture. Since jurisdiction does not include the architecture, the review policy has been that the signs are reviewed with respect to the design and color scheme of the building on which the sign/signs would be located. In reviewing the pad sites, the Board opted to make the signs conform to the building rather than try achieve uniform signs.

DISCUSSION:

A proposal to alter the existing Exxon sign can be considered, however, greater refinement of the sign design is warranted. It appears that the proposed canopy sign is a box sign, a sign type that has been discouraged on station canopies previously. These

signs are bulky in nature and appear as an appendage rather than an advertisement that is architecturally integrated with its sign area. To be consistent with previous decisions by the BAR, it is recommended that the canopy sign consist of channel letters. It should be noted that white channel letters were approved for the Sheetz station. The addition of the Exxon logo to the top of the gas pump meets the regulations; the color should be verified. The tiger logos at the bottom of the gas pumps are not before the BAR, as they do not meet the zoning regulations.

The Board should verify the proposed changes to the monument sign.

RECOMMENDATION:

Approval of the application is recommended subject to the canopy sign consisting of a channel-letter type sign, and clarification of the changes to the monument sign. The motion should state that the Tiger logos are removed from the application as these additional signs exceed the number of allowable signs for gas stations.

A handwritten signature in cursive script, appearing to read "Kristie Lalire".

Kristie Lalire, Planner



The Town of
**Leesburg,
Virginia**

MICHAEL E. TOMPKINS
Director of
Planning, Zoning & Development

25 West Market Street ■ Post Office Box 88 ■ 22075 ■ 703-777-2420 ■ Metro: 703-478-1821 ■ FAX: 703-771-2727

August 4, 1993

Mr. Christopher A. Taylor
The Spectra Group
325 Office Square Lane
Virginia Beach, VA 23462

Dear Mr. Taylor:

This letter serves as your official notification of the action taken by the Leesburg Board of Architectural Review (B.A.R.) on the application, CASE **BAR 93-47** for a Comprehensive Sign Plan, at the regularly scheduled meeting on August 2, 1993.

The Board of Architectural Review approved your request for a sign package as presented with the option to add a WASH sign and materials for the monument sign base match the buildings reflecting either gray or tan for the **Exxon Station** located in the Shenandoah Square Shopping Center at **984 Edwards Ferry Road**. Following completion of work, please contact staff for final inspection. Drawings or projects may not be altered without prior approval of the Board of Architectural Review.

Unless you have already done so, you will need to apply for a sign permit from the Leesburg Zoning Office. If you have any questions, or need to follow up on your permit application, please contact Kevin Lawlor, Assistant Zoning Administrator at 771-2772 for more information.

Sincerely,

Kristie Lalire
Staff, Board of Architectural Review

KL/ja

cc: Kevin P. Lawlor, Assistant Zoning Administrator

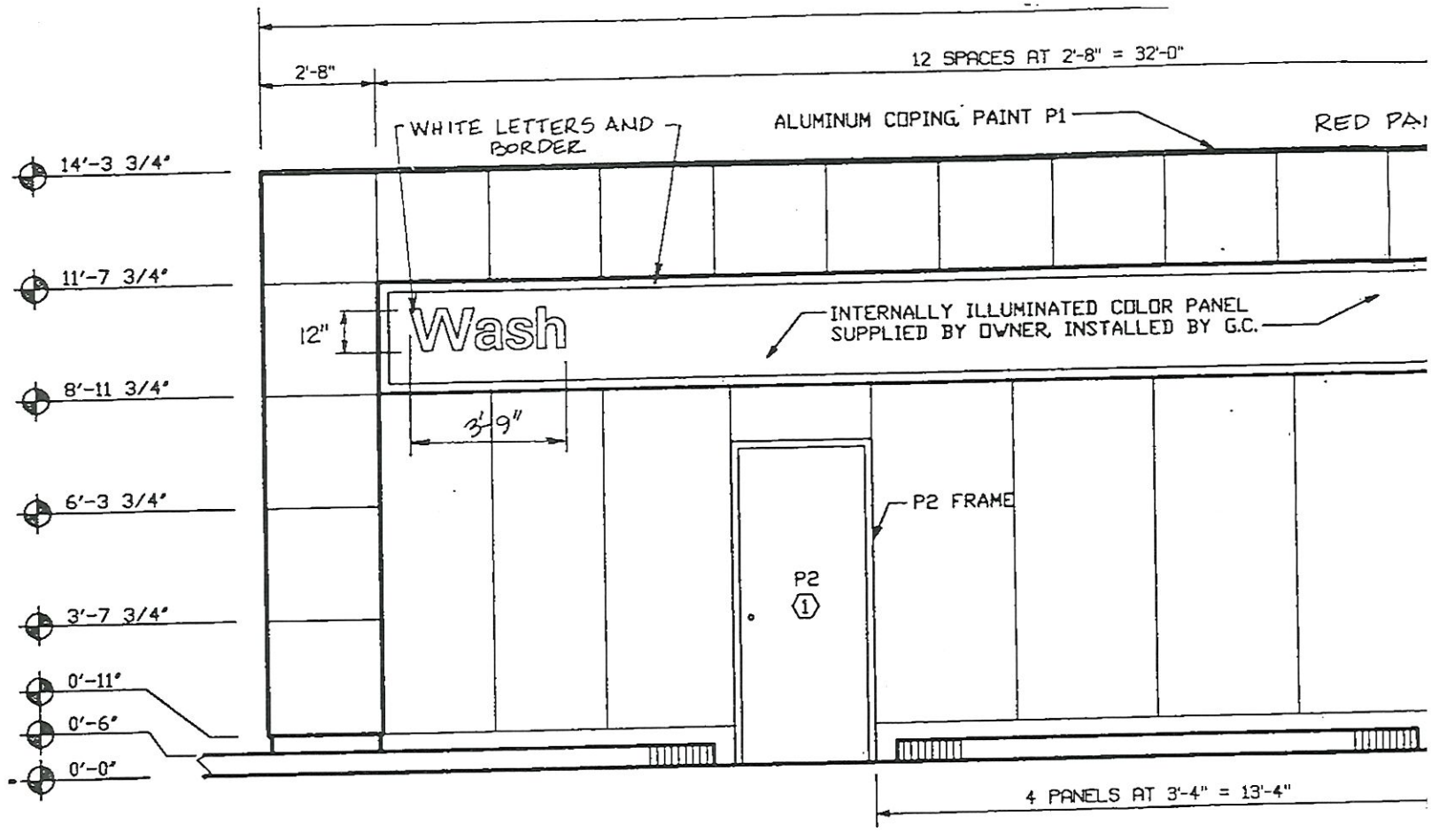

2 FRONT ELEVATION
 3S SCALE: 1/4" = 1'-0"
 EXTERIOR FINISH DIMENSIONS SHOWN

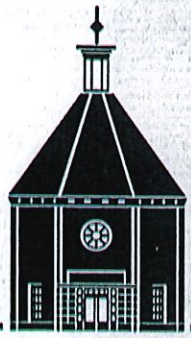

The Town of
**Leesburg,
Virginia**

25 West Market Street ■ P.O. Box 88 ■ 20178 ■ 703-777-2420 ■ Metro: 703-478-1821 ■ FAX: 703-771-2727 ■ www.leesburgva.org

August 21, 2002

Mr. Tim Ryan
22630 Davis Drive Suite 200
Sterling, Virginia 20614

Dear Mr Ryan:

This letter serves as your official notification of the action taken by the Leesburg Board of Architectural Review (B.A.R.) at the August 19, 2002 meeting on CASE BAR 02-80 for signs for the Exxon Station located at 984 Edwards Ferry Road NE.

The BAR approved the sign scheme that includes the red wall panels for the convenience store. Drawings or projects may not be altered without prior approval of the BAR.

Please find enclosed the sign permits. If you have any questions about your sign permit applications, please telephone Kevin Lawlor, Assistant Zoning Administrator, at 703 771-2765.

Sincerely,

Kristie Lalire
Preservation Planner

Enclosures

REPLACING 'TIGER MART' PANEL SIGN TO BE WITH SAME SIZE 'ON THE RUN' SIGN.

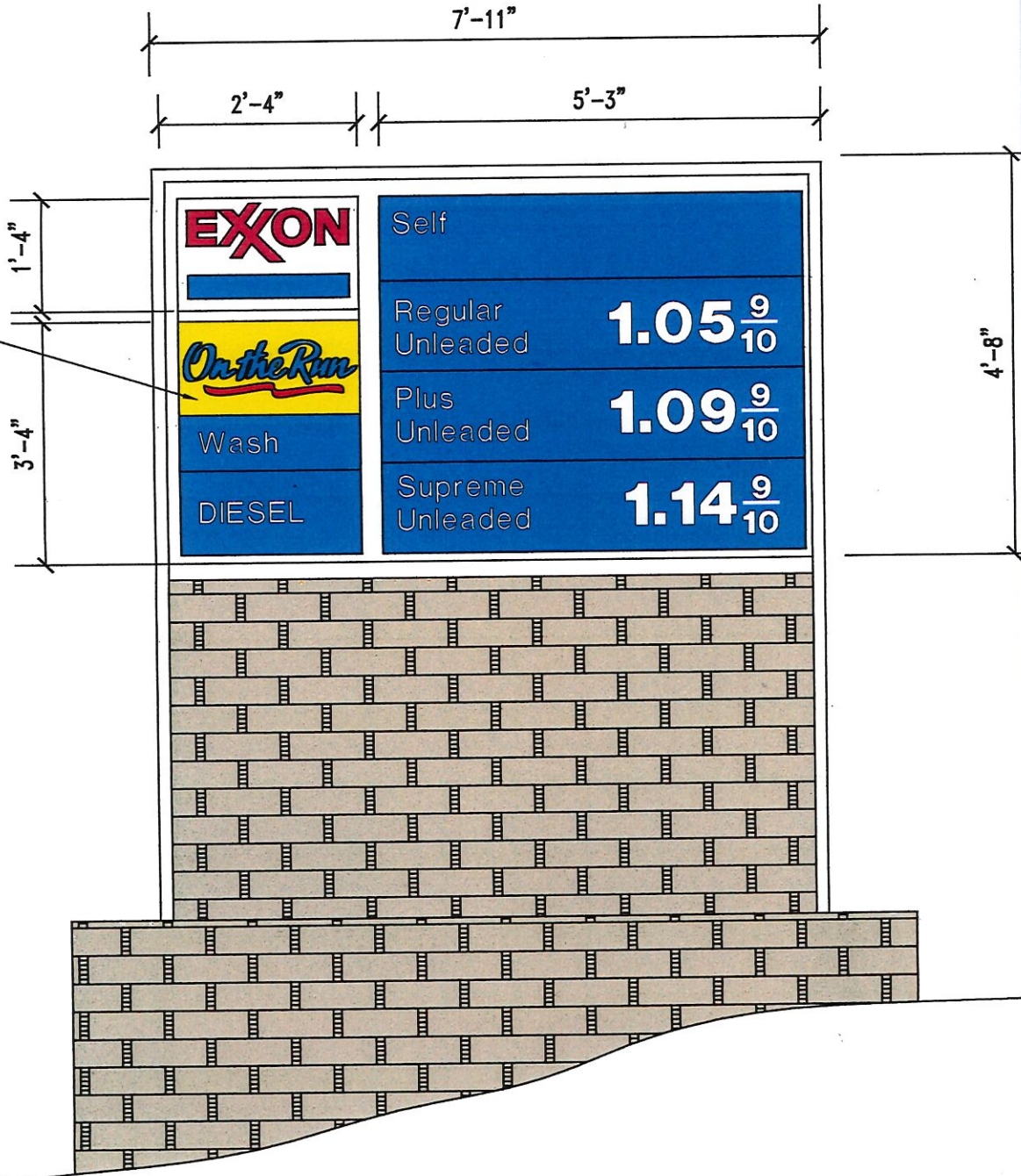

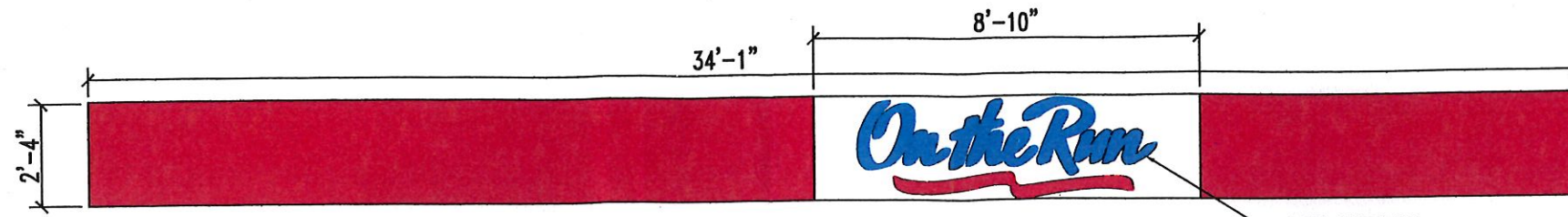

(A) PROPOSED "ON THE RUN" SIGN 79.41 S.F.

SCALE: 1"=4'

BLUE LETTERS

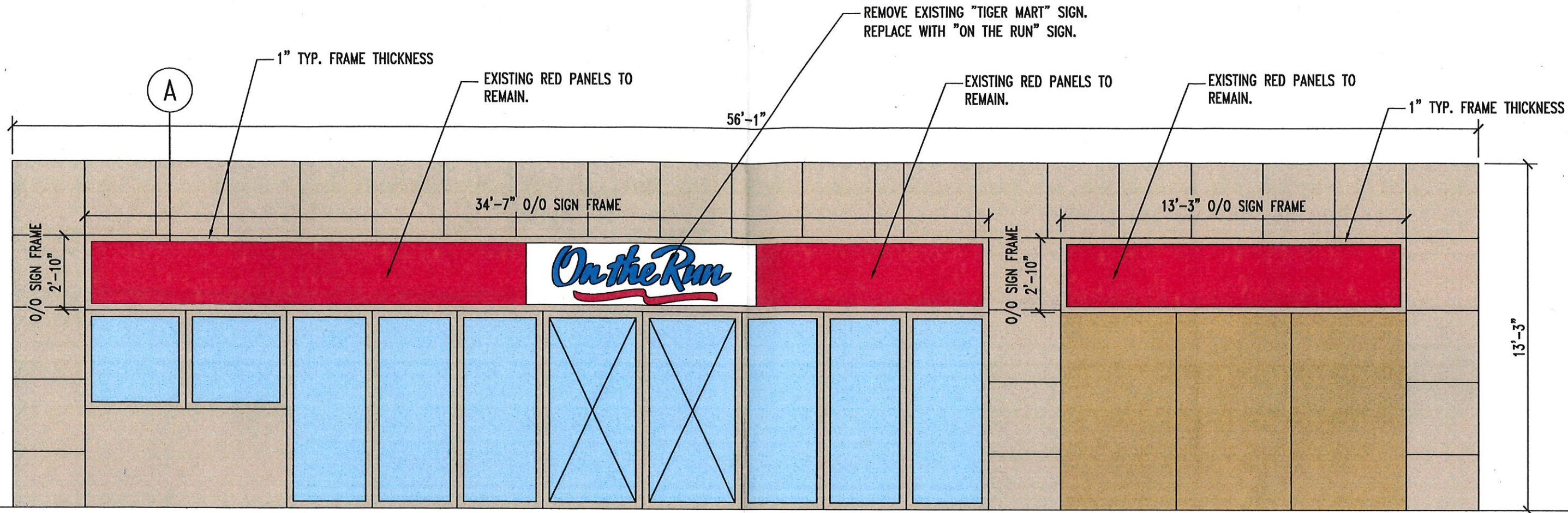

FRONT ELEVATION

SCALE: 1" = 4'

The
Town
of
Leesburg in Virginia

BOARD OF
ARCHITECTURAL
REVIEW

HISTORIC CORRIDOR OVERLAY DISTRICT
CERTIFICATE OF APPROVAL

Justin Latrine
STAFF, BOARD OF ARCHITECTURAL REVIEW

8/19/2002
DATE OF APPROVAL

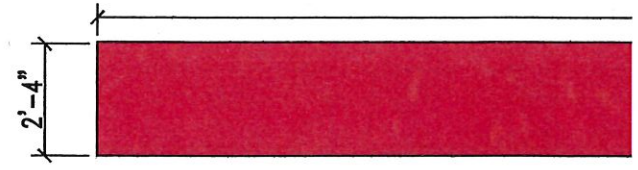

(A) PROPOSE