

## **A Public-Private Collaboration between the Town of Leesburg, VA Commission on Public Art and Friends of Leesburg Public Arts**

### **Summary:**

The Leesburg Commission on Public Art (COPA) has a sculpture on loan program, in cooperation with the Friends of Leesburg Public Arts. Called ArtsPARKs, the inaugural program will select 5 artists or artists' teams for a 2-year installation of public art (sculptures or other outdoor-appropriate artworks), along the paved walkway, located in Raflo Park along Harrison Street in downtown Leesburg, Virginia.

### **Project Description:**

The Town of Leesburg's Commission on Public Art (COPA) invites submissions for its ArtsPARKs project in Raflo Park. The program is open to all artists in the Washington, DC metro region. Artwork must be available for the duration of the 2-year display period (July 2020 to July 2022) and must be available for sale.

A panel of three appointed artists will make artwork selection.

Five (5) works of art will be selected. Artist or Artist Teams will be given an honorarium of \$1,000. **The artist/team will be responsible for the installation of the works onto a permanent concrete pad, configured with a metal pad with 4 predrilled holes.** See details and maximum dimensions below.

The art works will be available for sale and will be promoted by the Town of Leesburg and Friends of Leesburg Public Arts during a period of 2-years. **The artwork must remain for the full 2-year period and be de-installed at the end by the artist/team or buyer.**

### **Artwork Goals**

We will consider a wide variety of work including site specific work, work in a variety of sizes and scales, art with an interactive component, and proposed but not yet built works. Artwork deemed unsuitable for public display will not be considered. Accepted artwork must be stable, free standing, well fabricated and constructed of durable materials to withstand year round elements, including high winds, moisture, and bright sunlight. Sculpture must be suitable for interaction with the public, especially children. **It must be delivered complete and installed by the artist/team.**

There is no stated theme for the artwork(s) but the artworks should create excitement and interest for the community. Works could honor the rich history of Leesburg, the environs, reflect a vision for the future, or celebrate and inspire the community.

### **Artwork Location and Requirements**

The location of the ArtsPARKs is along the pathway that runs from the W&OD Bicycle Path to the Harrison Street crossing point to the Crescent Place Development. Five locations on both sides of the pathway have been sited with 30 inch round concrete pads. The concrete

## ArtsPARKs Call to Artists: 2020 - 2022

pads have been fitted with ¾" metal plates, pre-drilled with four corner holes to enable the bolting of the artworks to the pads. See attached detail entitled Plan View of Pedestal

COPA will choose placement for each artwork within the park. COPA reserves the right to reject any accepted artwork not meeting these requirements or if it differs from the original photos or sketches.

- **Selected artist/team will be responsible for the installation and de-installation for the artwork.** The method of installation will need to be approved by the Town of Leesburg, Parks & Recreation Department.
- Selected artist/team is responsible for insuring the work and making any repairs to the work due to vandalism.

### **Budget**

Each artist/team will receive an honorarium of \$1,000, provided to offset the costs related to installation/removal of the artwork. All artwork is to be available for sale with Friends of Leesburg Public Art (FOLPA) receiving a 20% commission to fund future rounds of ArtsPARKs. Any pieces sold before the de-installation date will be required to remain onsite until the end of the exhibition period. Transportation to the buyer would be the responsibility of the artist. De-installation will be scheduled for June 2020.

Friends of Leesburg Public Arts will be presenting a People's Choice Award. A public voting period of six months will be established and the winner will be announced at the 2021 Flower and Garden Show.

### **Artist Eligibility**

This call is open to artists and artist teams within the Washington DC Metro region. Emerging artists are encouraged to apply. There is no requirement that you have previous public art experience.

### **Application Requirements**

1. Up to 3 separate works can be entered.
2. Resume with contact information, website or Facebook page (if available) and any previous related experience.
3. Portfolio to include pictures (front, back, and detail) in 300 dpi jpeg format.
4. Description of proposed work with detailed sketches, etc. (*Must include: title, date, medium, height, depth, width, weight, base size, and price*).
5. Work must fit within the envelope shown on the attached Artwork Sizing Diagram.
6. If work is not complete at submission, please include detailed sketches with anticipated final measurements, base size, price, etc.
7. Artist statement – a written description of the work, including artist interpretation.

## ArtsPARKs Call to Artists: 2020 - 2022

### Timeline

November 27, 2019	Call open and posted online
February 7, 2020, 5pm	Submissions due
February 10, 2020	Advisory Panelists meet to review submissions
March 2, 2020	COPA recommends sculptures to Town Council
March 10, 2020	Town Council votes on recommendations
March 13, 2020	Artists notified
June 10 to 23, 2020	Coordination of previous sculpture removal/new work installed
On or about July 1, 2020	Unveiling Ceremony
June 2022	De-Installation of 2020 installations

### Selection Process

An advisory panel of 3 regional artists will review the submissions, and select the 5 finalists. The panel will send the recommendations to the Commission on Public Art who will review and clarify any technical issues with the designs. The Commission will then send the finalists to the Town Council for approval.

### Selection Criteria

- Originality/creativity
- Quality of materials and execution
- Appropriateness to the area and Town of Leesburg
- General community appeal
- Durability of the artwork (preference may be given to pieces requiring less maintenance and better sustainability of materials)
- Ease of installation
- Sale price of artwork
- Other evaluation criteria not outlined above may be considered as necessary

### Submission Address:

Applications may be submitted by the deadline February 7, 2020, 5pm online to: [ageiger@leesburgva.gov](mailto:ageiger@leesburgva.gov) or by mail to: Town of Leesburg, Commission on Public Art, 25 W Market St, Leesburg, VA 20176 ATTN: Anne Geiger, Senior Engineer

### Contact Information

For more information please contact: Donna Torraca, Chairman of the Commission on Public Art via email at: [DTorraca@leesburgva.gov](mailto:DTorraca@leesburgva.gov)

Attachments: Artwork Sizing Diagram  
Plan View of Pedestal

# ArtSparks Artwork Sizing Diagram

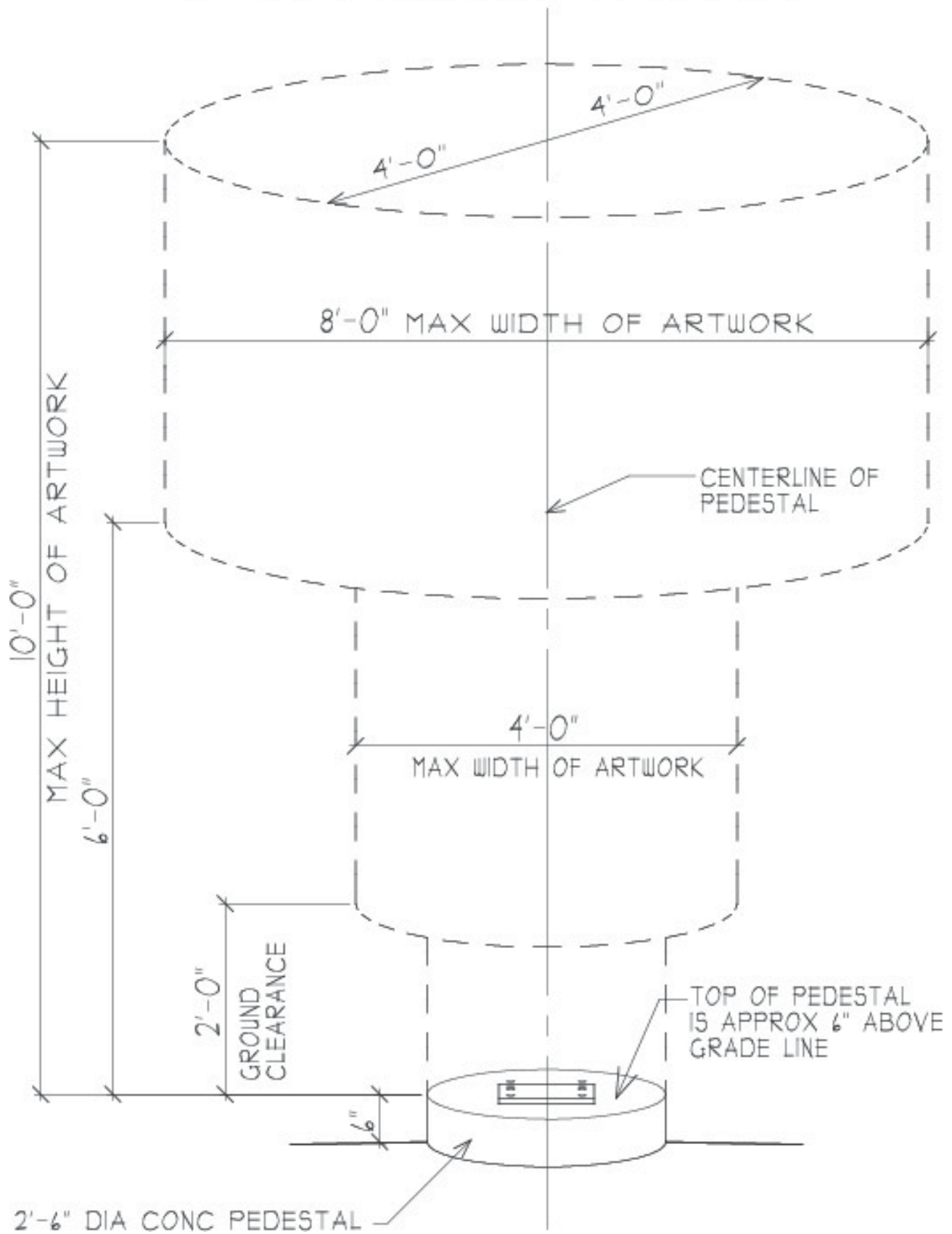

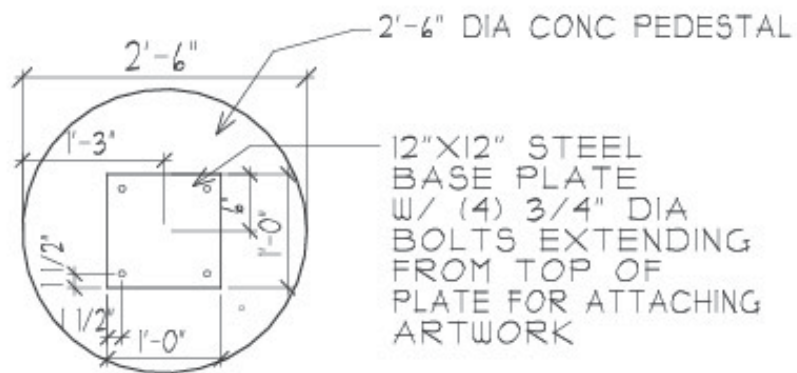

Plan View of Pedestal

3/4" = 1'-0"